

TOWARDS SEAMLESS PRODUCT STRUCTURE INFORMATION INTEGRATION

Paavo Kotinurmi &
TKK SoberIT

Ilse Becker
Valmet Automotive



Outline

- Motivation – current interoperability problems
- Key technologies and standards for helping in interoperability
 - Integration technologies
 - Content standards
- Proposed solutions
- Conclusions and future work



Overall B2B integration landscape

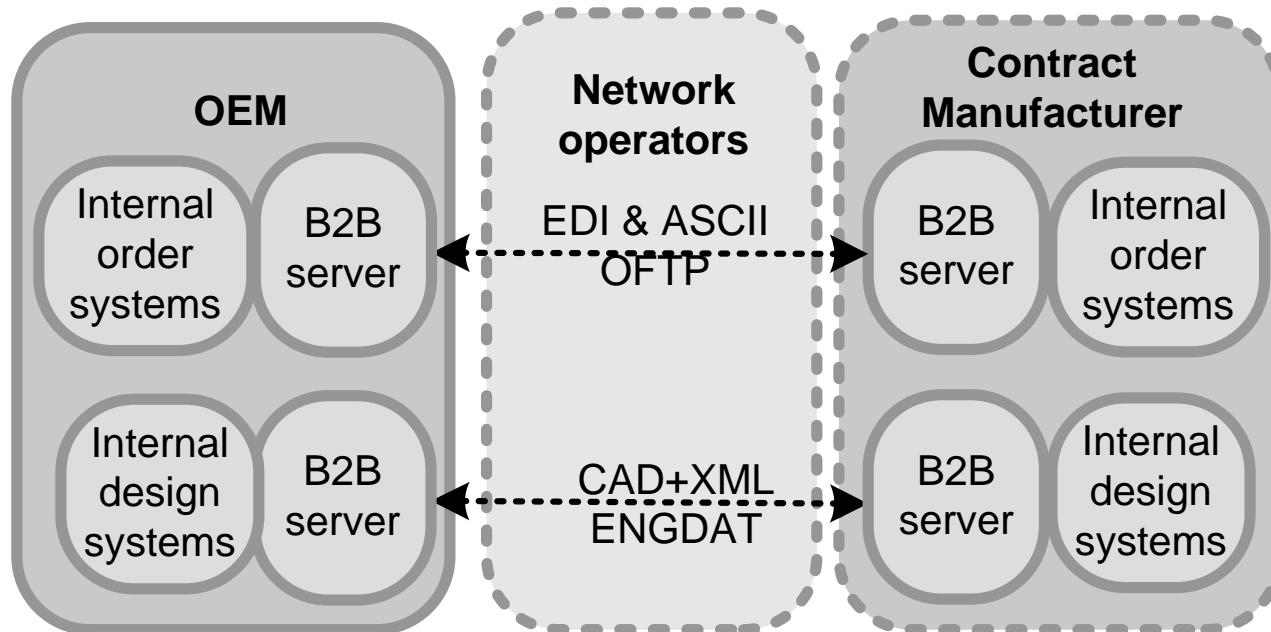

Motivation - product structure information

- Designs in 3D models, which need the positioning information
- Different Product Data Management (PDM)/Computer Aided Design (CAD) used with OEM and contract manufacturers
- The current system is point-to-point. Errors on position matrix with varying accuracy of systems (not isometric). Manual work, delays in processes

0,937074488	0,043796865	-0,346371532	0,999999999999998
0,346942786	-0,005951597	0,937867412	0,999999999999999
0,039014189	-0,999022729	-0,020772097	0,999999999999999
1,00000000003	0,999999999999997	0,999999999967	



**Version change → integration broken
(attributes names changed)**

Key underlying technologies

- EDI (ODETTE & ODETTE ENGDAT)
 - + widely used in industry, proven
 - - no content support for product information, inflexible
- STEP
 - + Used in automotive industry for CAD data exchange, EXPRESS language strong
 - - not widely used, requires special people and special tools
- XML
 - + widely used, known. Tool support excellent for validation, transformation, interface behaviour, process execution
 - - lots of competing standards using XML – limited semantic interoperability
- Semantic Web Services
 - + Support for semantics, stronger validation and reasoning capabilities
 - - still research. New to people and tools support still mostly lacking



Content standards for product information

- Odette ENGDAT
 - Standard for transferring product data between organizations
 - Defines a messaging envelope wrapping the engineering data.
 - ASCII, Europe-based
- RosettaNet
 - Global standards for B2B integration in IT, EC, SM industries
 - Defines Partner Interface Processes, related messages and secure messaging over Internet
- STEP
 - ISO standard 10303 that began standardisation in 1980:s
 - Defines EXPRESS modeling language and number of application protocols



Solution 1 – Applying content standards

- The benefit of standards (e.g. RosettaNet, ODETTE) is to shield from internal changes and providing extensible solution. Inter-company messaging interface need not be changed while internal system change.

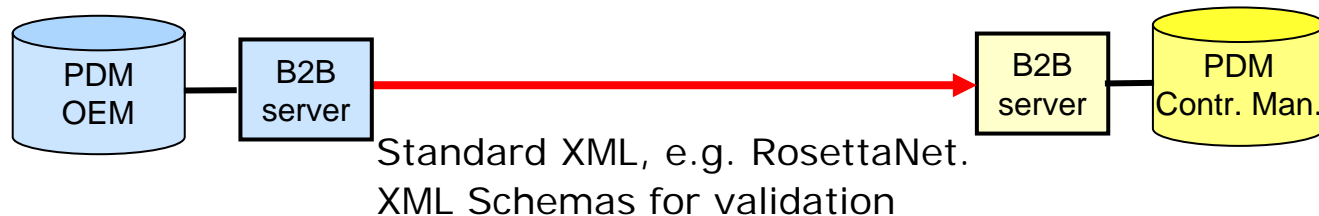

- The problems with position matrixes cannot still be solved. The expressivity of XML Schema does not allow to check complex contents.

0,937074488	0,043796865	-0,346371532	0,999999999999998
0,346942786	-0,005951597	0,937867412	0,999999999999999
0,039014189	-0,999022729	-0,020772097	0,999999999999999
1,00000000003	0,9999999999997	0,999999999967	

How e-business standard technologies help

- RosettaNet, ODETTE etc. establish common understanding of the terms
 - Covers checking enumerated values, data types and value ranges.
 - However, no computation supported or if the object is close to risky area (origo), then the check needs to be thorough.

```
<xs:element name="objekt">
  <xs:attribute name="state" type="lifeCycle"/>
  <xs:attribute name="xx" type="coordValue">
  <xs:attribute name="xy" type="coordValue">
</xs:element name="objekt">
<xs:simpleType name="coordValue">
  <xs:restriction base="xs:decimal">
    <xs:minInclusive value="-1"/>
    <xs:maxInclusive value="1"/>
  </xs:restriction>
</xs:simpleType>
```

Listing 1: XML Schema extract



Solution 2 –Semantic technologies

- Semantic technologies enable expressing rules on message contents
- It can be stated that the square of the values in columns or rows in between acceptable limits. Or that if certain condition is true (object near origo) the validation needs own extra rules

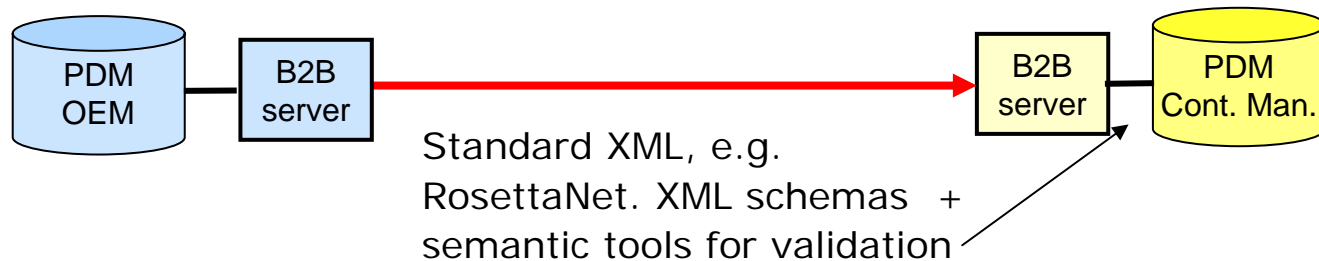

- Unnecessary manual handling can be avoided with increased automation. Only real errors need manual handling/checking.
- The semantic languages are more expressive, can represent all current constraints in existing schemas

How semantic technologies can improve on existing collaborations?

- Semantic technology (such as WSML) is stronger than XML Schemas
 - Relation between elements can be made explicit
 - Calculations can be performed. Counting square sums and summing up rows and columns. And having rules checking the results are within acceptable limits
 - This declaratively without custom coding
 - Constraints on elements in schema can be expressed
- Can act as the unifying data model. Stronger technology can represent things in weaker technologies.
- Content standards still needed to define the domain terminology



Conclusions and Future Work

- B2B content standards help to make integrations more loosely coupled
- Standards for IT industry (RosettaNet) or automotive industry (Odette) have similarities but both fail to provide solutions for the problem at hand
- Shortcomings of existing technologies can be solved using semantic web service technologies
 - Relation between elements in the schema (e.g. measurement units) can be made explicit
 - Calculations can be declaratively performed
- More work is needed to take the solutions towards the practice. Currently conceptual implementation



<closing_time>Any Questions ?</closing_time>

